

# TRANSMISSION TRANSPARENCY AND POTENTIAL CONVERGENCE OF OPTICAL NETWORK SOLUTIONS AT THE PHYSICAL LAYER FOR BIT RATES FROM $2.5 \text{ GB}\cdot\text{s}^{-1}$ TO $256 \text{ GB}\cdot\text{s}^{-1}$

Rajdi AGALLIU, Michal LUCKI

Department of Telecommunication Engineering, Faculty of Electrical Engineering,  
Czech Technical University in Prague, Technická 2, 166 27 Prague 6, Czech Republic

agallraj@fel.cvut.cz, lucki@fel.cvut.cz

DOI: 10.15598/aeec.v15i5.2502

**Abstract.** *In this paper, we investigate optical network recommendations GPON and XG-PON with triple-play services in terms of physical reach, number of subscribers, transceiver design, modulation format and implementation cost. Despite trends to increase the bit rate from  $2.5 \text{ Gb}\cdot\text{s}^{-1}$  to  $10 \text{ Gb}\cdot\text{s}^{-1}$  and beyond, TDM-PONs cannot cope with bandwidth requirements of future networks. TDM and WDM techniques can be combined, resulting in improved scalability. Longer physical reach can be achieved by deploying active network elements within the transmission path. We investigate these options by considering their potential coexistence at the physical layer. Subsequently, we analyse the upgrade of optical channels to  $100 \text{ Gb}\cdot\text{s}^{-1}$  and  $256 \text{ Gb}\cdot\text{s}^{-1}$  by using advanced modulation formats, which combine polarization division multiplexing with coherent detection and digital signal processing. We show that PDM-QPSK format is suitable for  $100 \text{ Gb}\cdot\text{s}^{-1}$  systems and PDM-16QAM is more beneficial at  $256 \text{ Gb}\cdot\text{s}^{-1}$ . Simulations are performed in the OptSim software environment.*

## Keywords

*Optical networks, optical transceiver, polarization division multiplexing, time division multiplexing, wavelength division multiplexing.*

## 1. Introduction

The primary multiplexing technique for Passive Optical Networks (PON) is the Time Division Multiplexing

(TDM), and Gigabit PON (GPON) [1] is one of the most widely deployed recommendations [2]. Due to the progressive evolution of networks, TDM-PONs do not cope with bandwidth and power budget requirements for future use, although other standards with higher bit rates have also been proposed, such as XG-PON [3]. The solution can be Wavelength Division Multiplexing (WDM) PONs, which mitigate these problems by separating Optical Network Units (ONU) via physical wavelengths. Enhanced physical reach to ONUs can be achieved by using optical amplification [4]. This leads to the concept of long-reach PONs [5]. The combination of WDM and TDM seems to be the most promising. In this paper, we investigate PONs with triple-play services in terms of optical reach, number of subscribers, transceiver construction, modulation and implementation cost. We search for possibilities of how to enhance the bandwidth efficiency meanwhile investigating the coexistence of Optical Access Network (OAN) solutions at the physical layer. Coexistence in this context means the migration in the same optical distribution network. For PON solutions we consider the GPON and XG-PON standards due to their wider deployment in Europe. GPON and XG-PON are intended to coexist together by applying identical "colourless" ONUs [6], which brings cost savings, easier network planning and its maintenance. Simultaneously, we consider the upgrade of transmission rates beyond XG-PON, such as  $100 \text{ Gb}\cdot\text{s}^{-1}$  and  $256 \text{ Gb}\cdot\text{s}^{-1}$  per optical channel, by deploying advanced modulation formats and comparing them to each other to find out the most suitable solution for future network architectures. Simulations were performed in OptSim environment [7].

## 2. State of Art

The triple-play service is implemented as a combination of data, voice and video signals. Data and voice downstream components are transmitted at a wavelength range of 1480–1500 nm in GPON, 1575–1580 nm in XG-PON, and video within the 1550–1560 nm range. Allocation of the wavelength ranges, which is recommended by Telecommunication Standardization Sector of the International Telecommunications Union (ITU-T) [3], is selected in such a way to avoid interferences between GPON and XG-PON signals. The first world field trial results of the XG-PON can be found in [8]. Authors in [9] experimentally demonstrate the 10 Gb·s<sup>-1</sup> optical access network with downstream traffic at 1550 nm wavelength using an Erbium Doped Fibre Amplifier (EDFA) to reach the maximum distance of 62 km over Standard Single Mode Fibre (SSMF) and with 256 subscribers. Besides the deployment of EDFA, modulation is a key factor, which can significantly improve the transmission system. As an example, while comparing the Return to Zero (RZ) and Non Return to Zero (NRZ) modulation formats in a co-existing GPON and XG-PON system, the physical reach is greater in case of RZ deployment due to its better immunity to fibre non-linearities [10]. Either GPON, or its 10 enhanced recommendations is based on TDM, which has its limitations [11]. Some solutions beyond XG-PON bit rate are reviewed in [12]. WDM-PON is considered to be the most practical solution for capacity expansion. However, the 10 Gb·s<sup>-1</sup> ONUs in pure WDM-PONs are too excessive for next 10 year [13].

Authors in [14] propose a hybrid architecture, which combines TDM and WDM capabilities to enable longer optical reach and higher scalability. The main reasons behind the deployment of such networks are to meet increasing capacity demand and user density requirements, while ensuring that the cost per unit bandwidth is minimized [15]. The upgrade of optical channels to higher bit rates deals with limitations at the physical layer, such as Chromatic Dispersion (CD), polarization mode dispersion and fiber nonlinearities. The selection of an efficient modulation format is a key design step to resolve these issues. Introduction of new techniques that combine Polarization Division Multiplexing (PDM), coherent detection and Digital Signal Processing (DSP) can mitigate some of the physical limitations that ordinary intensity or phase-based modulations have, as shown in [16], where an 8 Tb·s<sup>-1</sup> transmission with 100 Gb·s<sup>-1</sup> PDM Quadrature Phase Shift Keying (PDM-QPSK) channels over low dispersion fibers is investigated. PDM-QPSK proves to perform well at 100 Gb·s<sup>-1</sup> in terms of physical reach, spectral efficiency, Optical Signal to Noise Ratio (OSNR), CD and differential group delay tolerances [17]. Generally,

PDM combined with Quadrature Amplitude Modulation (QAM) formats seem to currently have the highest attention for transmission rates over 100 Gb·s<sup>-1</sup> [18] and [19]. Experiment in [20] shows the suitability of PDM-QPSK and PDM-16QAM in long-haul and submarine systems with span lengths over 100 km. We investigate in this paper both PDM-QPSK and PDM-16QAM formats in terms of spectral efficiency, channel spacing, physical reach, Bit Error Rate (BER) and OSNR.

## 3. Methods

We simulate the coexistence of GPON, XG-PON and video services to investigate for potential bandwidth utilization improvements and to show the benefits of convergence of multiple access network solutions in hybrid PONs, which is not yet implemented in practical solutions, and we strongly recommend it. We focus on the downstream traffic for simplification purposes; however this does not restrict the generality of this investigation. The simulation scheme is shown in Fig. 1.

We consider the GPON/XG-PON recommendations from ITU-T for the TDM-PON domain to allow triple-play service delivery up to 64 subscribers. We implement this TDM system above a WDM domain, and we investigate such hybrid PONs in terms of optical spectrum, modulation, optical amplification etc. Figure 1 is divided into three parts: Optical Line Terminal (OLT) that contains the data/voice/video transmitters, Optical Distribution Network (ODN) that includes the transmission path components and ONU, which represents end-user equipment. The TDM segment is related to standard TDM-PON architecture. The Internet component is represented by a data link with 2.5 Gb·s<sup>-1</sup> downstream bandwidth for GPON and 10 Gb·s<sup>-1</sup> download bandwidth for XG-PON. Data transmitters produce NRZ modulated signals. The voice component can be Voice over Internet Protocol service. For simplification purposes, we use a 16-QAM SubCarrier Multiplexed system, although other QAM variants are more typical to carry digital video stream in radio frequency channels. The 800 Mb·s<sup>-1</sup> data stream for the video signal is launched to the QAM modulator. The obtained electrical signal is subsequently processed by an optical modulator driven by a laser similarly as in the data/voice transmitter. The output power of each transmitter is set to 0 dBm. Transmission media consists of an SSMF with 0.2 dB·km<sup>-1</sup> attenuation at 1550 nm, an optical splitter for signal distribution among 64 subscribers and a drop-off cable of several meters. At the receiver's side, the optical signal of each channel is filtered, and the electrical signal from each of the receivers is measured in terms of eye diagram, Q-factor, BER. Such scenario

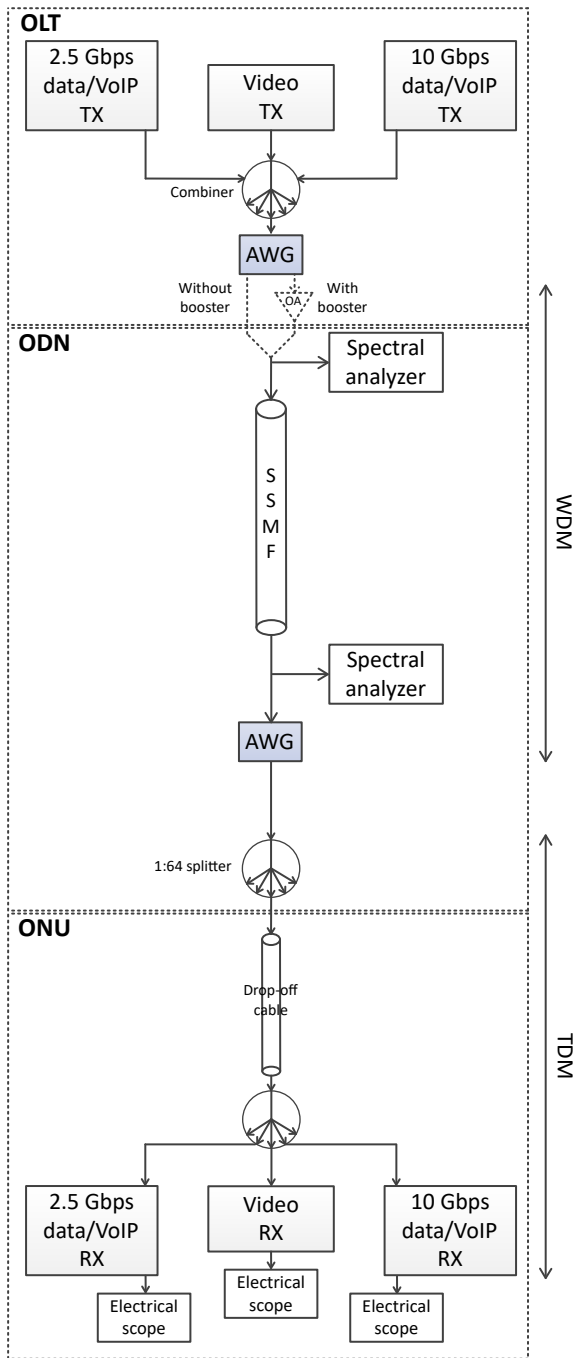

Fig. 1: TDM/WDM-PON system with GPON/XG-PON and video access architecture.

is also simulated for an active optical network by deploying a single optical amplifier, used as a booster, to figure out the benefits of introducing an optical amplifier versus the cost of such implementation. Subsequently, we compare different transceivers from their design point of view. The upgrade of optical channels to  $100 \text{ Gb}\cdot\text{s}^{-1}$  and  $256 \text{ Gb}\cdot\text{s}^{-1}$  is focused in this paper on the design of PDM-QPSK and PDM-16QAM transceivers. Figure 3 shows the design of PDM-QPSK transmitter. The first part of the transmitter con-

sists of four pseudorandom binary sequence generators (PRBS in Fig. 3), NRZ drivers, low-pass filters (LPF in Fig. 3), and Mach-Zehnder Modulators (MZM) driven by a Continuous-Wave (CW) laser. They generate the required phase-based modulated signals through Phase Modulators (PM), which are subsequently incorporated into PDM by rotating the polarization of one branch [7].

At the receiver side, optical signals are filtered at the required frequency by using a band-pass filter (BPF in Fig. 2). A single ended  $90^\circ$  hybrid with local oscillator and four PIN photodiodes enable the coherent detection. Subsequently, signals travel through transimpedance amplifiers (TIA in Fig. 4), LPF filters and then through an ideal Electronic Dispersion Compensation (EDC) with 4 electrical input signals and 4 electrical output signals.

An error counting is then applied on the four signals. The EDC block implements an ideal EDC, which applies the same amount of compensation on all signals. The last block in the PDM-QPSK receiver consists of a memoryless blind receiver, which separates polarizations, as well as in-phase and quadrature components by applying the Constant Modulus and Viterbi & Viterbi algorithms [7]. In a similar fashion, PDM can be applied also on other formats, such as QAM. Based on similar design principles, a PDM-16QAM transceiver has been built in OptSim software environment. We propose this format to be a standard solution in the upcoming years for terabit transmissions. The simulation scheme for comparing PDM-QPSK and PDM-16QAM formats in Dense WDM (DWDM) systems is given in Fig. 2. The dispersion compensation is applied by deploying Non-Zero dispersion-shifted fibers with  $0.2 \text{ dB}\cdot\text{km}^{-1}$  loss and  $\text{CD } 4 \text{ ps}\cdot\text{nm}^{-1}\cdot\text{km}^{-1}$  at the considered band.

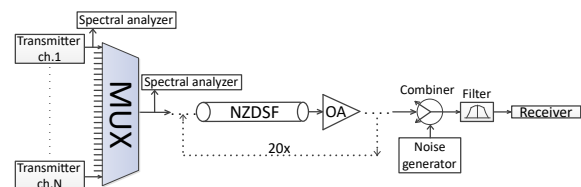

Fig. 2: Simulation scheme for PDM-QPSK and PDM-16QAM DWDM systems.

The purpose of this simulation is to figure out the efficiency of PDM-QPSK and PDM-16QAM in long-haul transmission systems, consisting of hundreds of kilometres. The optical signal is noise loaded to extract BER as the function of OSNR. Each fiber span is 100 km long and separated from each other by amplifiers (OAs in Fig. 2) with a fixed gain around 20 dB. We consider in transmitters 7 % bit rate overhead for Forward Error Correction (FEC). Transmitted power is set to 3 dBm for comparison purposes. PDM-QPSK

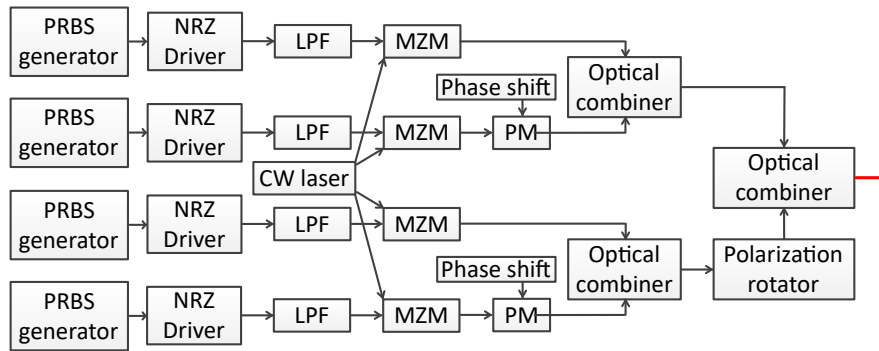

Fig. 3: Transmitter design of PDM-QPSK.

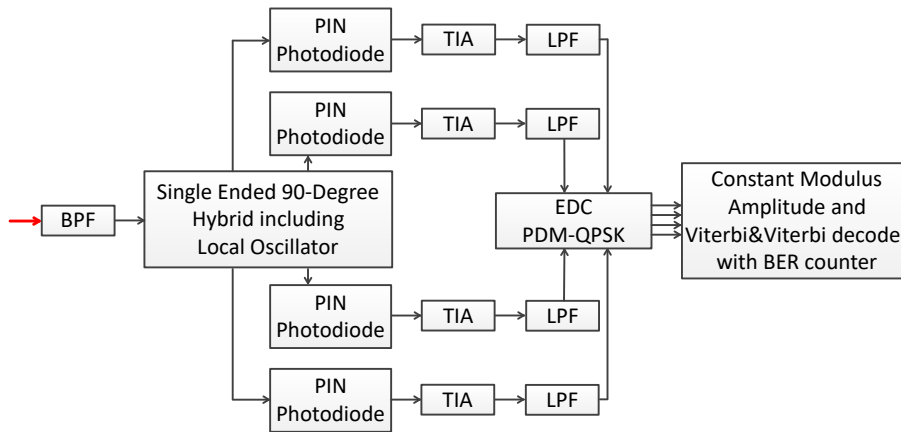

Fig. 4: Receiver design of PDM-QPSK.

and PDM-16QAM systems with 50 GHz channel grid and 32 GBd baud rate result in a per channel bit rate of  $128 \text{ Gb}\cdot\text{s}^{-1}$  in case of PDM-QPSK and  $256 \text{ Gb}\cdot\text{s}^{-1}$  in case of PDM-16QAM including FEC overheads. Simulations are based on the Time Domain Split-Step method [7].

### 4. Results and Discussion

The TDM/WDM-PON is modelled as per simulation setup given in Fig. 1. We search for the maximum allowed wavelengths within the GPON/XG-PON bandwidth ranges as per ITU-T. The aim of such simulation is to find out the possibilities for efficient bandwidth utilization and minimization of costs. The WDM technique is also beneficial for future network growth. Simulations as per Fig. 1 showed that we could use 0.4 nm (50 GHz) spacing between GPON and XG-PON channels, as can also be seen from the overall optical spectrum of this network in Fig. 5. It is possible to fit 50 GPON wavelength channels and 12 XG-PON channels for the download traffic estimated BER less than  $10^{-12}$ , and Q-factor higher than 7.035 (typical values), respectively. This means that the hybrid PON based

on this WDM would allow triple-play service distribution up to  $50 \times 64$  subscribers or  $12 \times 64$  subscribers using GPON or XG-PON in the time domain, respectively.

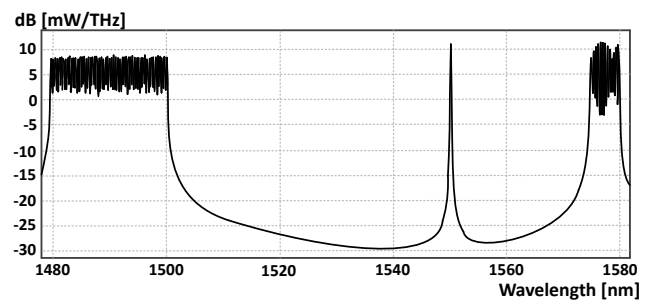

Fig. 5: Spectrum for triple-play services and coexistence of multiple GPON/XG-PON channels in a TDM/WDM-PON.

Installation of an optical amplifier has been considered as well. Installation of a single amplifier can significantly extend the physical reach of PONs, including hybrid solutions. Few possibilities come into consideration while considering optical amplification. We can either deploy an amplifier after the Arrayed Waveguide Grating (AWG) at the OLT side, before the AWG at the ONU side or use it as an in-line amplifier. De-

ployment outside this path would not be efficient since the amplification had to be done separately on a wavelength basis. The use of an in-line amplifier would not also be efficient from the cost and implementation perspective, as the provider had to introduce an active device in the middle of the transmission path. We have compared the remaining two choices in terms of BER, Q-factor and optical reach. We selected an amplifier with gain 10 dB as a reference. The results showed that the reach could be extended to 35 km while using a booster. Deployment of the optical amplifier at the ONU side could enable up to 31 km. The proposed solution with a booster is the best choice as it combines benefits of TDM, WDM and AONs.

NRZ is the recommended modulation format by ITU-T for GPON/XG-PON. We investigate also other intensity formats to search for significant improvements at the cost of the transmitter's construction. We have compared NRZ, RZ and Carrier-Suppressed RZ (CSRZ) formats. We found that RZ format is not beneficial for the hybrid PON primarily due to its wider spectrum, resulting in a higher interference between adjacent channels in the wavelength domain. The CSRZ signalling brought just a slight improvement compared to NRZ due to its central peak suppression at the carrier frequency, causing this reduced power to be distributed in other areas of the spectrum with real carried traffic. Nevertheless, due to its insignificant improvement and higher transmitter requirements, we propose to keep the NRZ format and deploy the scenario with a booster. Such solution proved to provide the best choice for scalable and future-proof network systems. In Fig. 6 and Fig. 7, we show the BER and Q-factor values for both GPON and XG-PON.

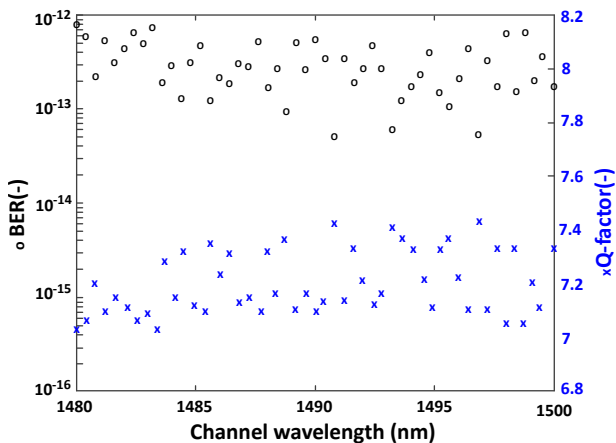

Fig. 6: Q-factor (crosses) and BER (circles) for GPON downstream channels in a hybrid TDM/WDM-PON.

As can be seen from the diagrams, the proposed hybrid TDM/WDM-PON with a booster and 35 km long SSMF proves to have acceptable BER and Q-factor values, for each of the channels, either for GPON or

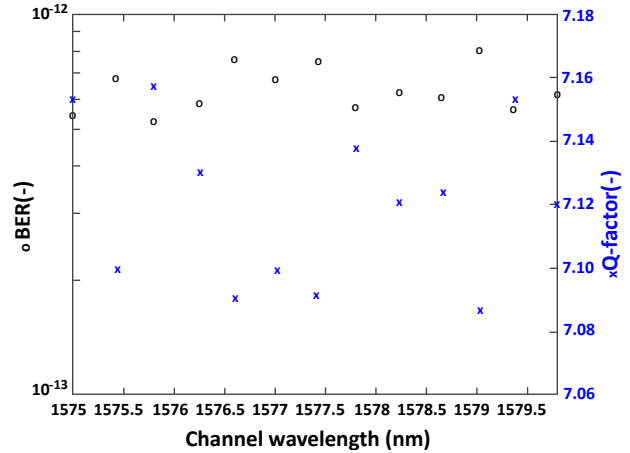

Fig. 7: Q-factor (crosses) and BER (circles) for XG-PON downstream channels in a hybrid TDM/WDM-PON.

XG-PON WDM channels. We highly recommend this solution for the next generation of PONs not only because of the physical reach, capacity and number of users that it can handle, but also because it doesn't introduce any change in the ODN, which makes the migration from the current network infrastructure easier its deployment and maintenance more efficient.

Subsequently, we focus on the upgrade of transmission rates to 100 Gb·s<sup>-1</sup> and beyond per optical channel, by using modulation formats PDM-QPSK and PDM-16QAM. The high spectral efficiency of PDM-QPSK at 100 Gb·s<sup>-1</sup> can be noticed at first glance from its optical spectrum, which is shown in Fig. 8.

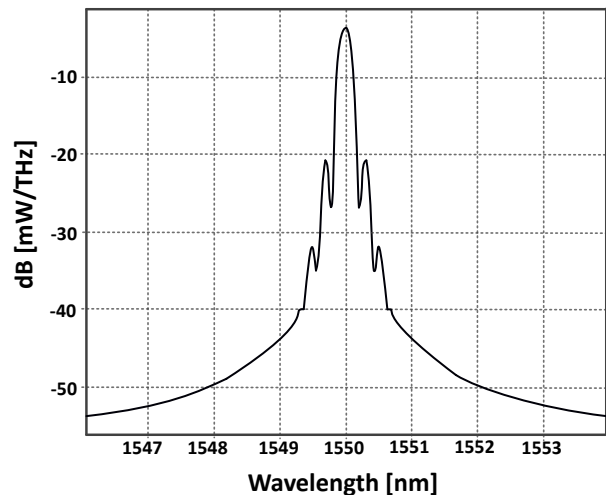

Fig. 8: Spectrum of a 100 Gb·s<sup>-1</sup> PDM-QPSK modulated signal.

We could find that the maximum acceptable channel spacing at 100 Gb·s<sup>-1</sup> is 50 GHz [21]. The parameters of optical filters were fine-tuned, and we found out PDM-QPSK could work fine up to 2000 km as per the simulation setup given in Fig. 2. The sim-



ulated pre-FEC value for all four signals was in the order of  $10^{-4}$  for 20 dB span loss. This proves the suitability of this format in  $100 \text{ Gb}\cdot\text{s}^{-1}$  transmissions over hundreds of km, while using appropriate dispersion compensation techniques and in-line amplification, among others. The combination of PDM with QAM is more promising for higher transmission rates over long distances. The measured optical spectrum of PDM-16QAM is given in Fig. [9].

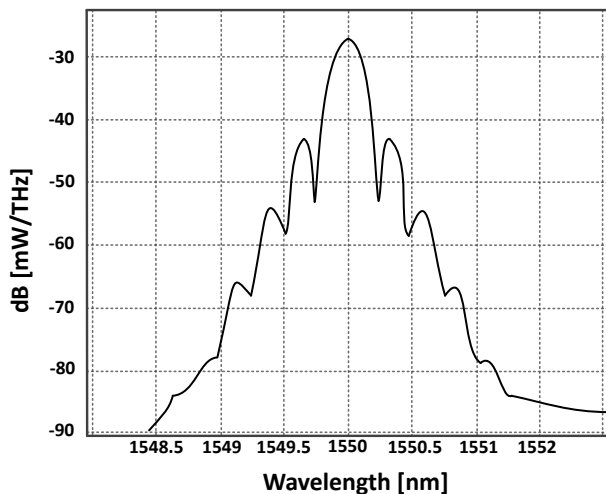

Fig. 9: Spectrum of a  $256 \text{ Gb}\cdot\text{s}^{-1}$  PDM-16QAM modulated signal.

We compared PDM-QPSK and PDM-16QAM in the DWDM system with 50 GHz grid for few channels at a baud rate of 32 GBd. This results in a per channel bit rate of  $128 \text{ Gb}\cdot\text{s}^{-1}$  in case of PDM-QPSK and  $256 \text{ Gb}\cdot\text{s}^{-1}$  in case of PDM-16QAM, including FEC overheads. The spectral efficiency for PDM-QPSK is  $2.56 \text{ b}\cdot\text{s}^{-1}\cdot\text{Hz}^{-1}$  (i.e.  $128 \text{ Gb}\cdot\text{s}^{-1}/50 \text{ GHz}$ ), meanwhile for PDM-16QAM is  $5.12 \text{ b}\cdot\text{s}^{-1}\cdot\text{Hz}^{-1}$  (i.e.  $256 \text{ Gb}\cdot\text{s}^{-1}/50 \text{ GHz}$ ). This means that PDM-16QAM offers double spectral efficiency compared to PDM-QPSK. However, this comes at the cost of higher required OSNR at a given BER. Specifically, the required OSNR for a pre-FEC BER of  $10^{-3}$  is 13.5 dB for PDM-QPSK and 21 dB for PDM-16QAM.

## 5. Conclusion

We investigated different PON solutions, starting from the pure TDM-PON architectures providing triple-play services and possible coexistence of GPON and XG-PON. Subsequently, we simulated the hybrid PONs that combines TDM and WDM, where each of the wavelengths is deployed in an independent TDM domain. We proved that the combination of WDM and TDM seems to be the most promising and such solution benefits in cost-effectiveness, flexibility and ex-

tendibility. System performance increased further by deploying a booster, which could extend the physical reach. The most promising formats for transmission rate of  $100 \text{ Gb}\cdot\text{s}^{-1}$  and beyond per optical channel combine PDM, coherent detection and DSP at the cost of higher design complexity, power consumption and faster circuits. We recommend using PDM-QPSK at  $100 \text{ Gb}\cdot\text{s}^{-1}$  and PDM-16QAM at  $256 \text{ Gb}\cdot\text{s}^{-1}$ , including DWDM systems with down to 50 GHz channel spacing. By proper tuning of simulation parameters for the DWDM transmission system, PDM-QPSK could carry data traffic over hundreds of km while using dispersion compensation techniques and optical amplification. Combination of PDM with QAM brought more benefits. PDM-16QAM could double the spectral efficiency of PDM-QPSK, at the cost of higher required OSNR at a given BER.

## Acknowledgment

This work has been supported by the CTU grant under project SGS16/227/OHK3/3T/13.

## References

- [1] ITU-T Recommendation G.984.1. *Gigabit-capable passive optical networks (GPON): General characteristics*. Geneva: ITU-T, 2008.
- [2] GROBE, K. and J. P. ELBERS. PON Evolution from TDMA to WDM-PON. In: *Optical Fiber communication/National Fiber Optic Engineers Conference*. San Diego: IEEE, 2008, pp. 1–7. ISBN 978-1-55752-856-8. DOI: 10.1109/OFC.2008.4528293.
- [3] ITU-T Recommendation G.987.1. *10-Gigabit-capable passive optical networks (XG-PON): General requirements*. Geneva: ITU-T, 2010.
- [4] LATAL, J., P. KOUDELKA, P. SISKÁ, J. VI-TASEK and V. VASINEK. WDM-PON network simulation with different implementation of optical amplifier in the line. In: *Novel Optical Systems Design and Optimization XVII*. San Diego: SPIE, 2014, pp. 1–16. ISBN 978-1-62841-220-8. DOI: 10.1117/12.2060112.
- [5] ITU-T Recommendation G.984.7. *Gigabit-capable passive optical networks (GPON): Long reach*. Geneva: ITU-T, 2010.
- [6] MULLEROVA, J., D. KORCEK and M. DADO. On wavelength blocking for XG-PON coexistence with GPON and WDM-PON networks. In: *14th International Conference on Transparent*

- Optical Networks*. Coventry: IEEE, 2012, pp. 1–4. ISBN 978-1-4673-2227-0. DOI: 10.1109/IC-TON.2012.6253748.
- [7] RSOFT DESIGN GROUP. OptSim Application Notes and Examples. OptSim User Guide. OptSim models reference. 2010. Software manuals.
- [8] JAIN, S., F. EFFENBERGER, A. SZ-ABO, Z. FENG, A. FORCUCCI, W. GUO, Y. LUO, R. MAPES, Y. ZHANG and V. O'BYRNE. World's First XG-PON Field Trial. *Journal of Lightwave Technology*. 2011, vol. 29, no. 4, pp. 524–528. ISSN 0733-8724. DOI: 10.1109/JLT.2010.2104313.
- [9] BORIBON, B., D. WORASUCHEEP, S. SHIMIZU and N. WADA. Computation and experiments of 10 Gb-s<sup>-1</sup> optical access network with long reach and a large number of subscribers. In: *12th International Conference on Electrical Engineering/Electronics, Computer, Telecommunications and Information Technology*. Hua Hin: IEEE, 2015, pp. 1–6. ISBN 978-1-4799-7961-5. DOI: 10.1109/ECTICon.2015.7206934.
- [10] KAUR, A., M. L. SINGH and A. SHEETAL. Comparison of RZ and NRZ data formats for co-existing GPON and XG-PON system. In: *International Conference on Advanced Nanomaterials and Emerging Engineering Technologies*. Chennai: IEEE, 2013, pp. 666–669. ISBN 978-1-4799-1377-0. DOI: 10.1109/ICANMEET.2013.6609379.
- [11] HOOD, D. and L. LU. Current and future ITU-T PON systems and standards. In: *17th Opto-Electronics and Communications Conference*. Busan: IEEE, 2012, pp. 125–125. ISBN 978-1-4673-0976-9. DOI: 10.1109/OECC.2012.6276402.
- [12] ELBERS, J. P. and K. GROBE. Optical access solutions beyond 10G-EPON/XG-PON. In: *Optical Fiber Communication Conference*. San Diego: OSA, 2010, pp. 1–3. ISBN 978-1-4673-0976-9. DOI: 10.1364/OFC.2010.OTuO1.
- [13] LEI, J. Architecture Analysis of Hybrid TDM/WDM PON. In: *Technodocbox* [online]. 2014. Available at: [http://technodocbox.com/Internet\\_Technology/\67159483-Architecture-analysis-of-hybrid-tdm-wdm-pon.html](http://technodocbox.com/Internet_Technology/\67159483-Architecture-analysis-of-hybrid-tdm-wdm-pon.html).
- [14] ABDALLA, M. E., S. M. IDRUS and A. B. MOHAMMAD. Hybrid TDM-WDM 10G-PON for high scalability next generation PON. In: *Industrial Electronics and Applications Conference*. Melbourne: IEEE, 2013, pp. 1448–1450. ISBN 978-1-4673-6320-4. DOI: 10.1109/ICIEA.2013.6566595.
- [15] WONG, E. Next-Generation Broadband Access Networks and Technologies. *Journal of Lightwave Technology*. 2012, vol. 30, iss. 4, pp. 597–608. ISSN 0733-8724. DOI: 10.1109/JLT.2011.2177960.
- [16] RENAUDIER, J., O. BERTRAN-PARDO, G. CHARLET, M. SALSU, H. MARDOYAN, P. TRAN and S. BIGO. 8 Tb-s<sup>-1</sup> long haul transmission over low dispersion fibers using 100 Gb-s<sup>-1</sup> PDM-QPSK channels paired with coherent detection. *Bell Labs Technical Journal*. 2010, vol. 14, iss. 4, pp. 27–45. ISSN 1089-7089. DOI: 10.1002/bltj.20402.
- [17] LACH, E. and W. IDLER. Modulation formats for 100G and beyond. *Optical Fiber Technology*. 2011, vol. 17, iss. 5, pp. 377–386. ISSN 1068-5200. DOI: 10.1016/j.yofte.2011.07.012.
- [18] XIA, T. J., G. A. WELLBROCK, H. MING-FANG, Z. SHAOLIANG, H. YUE-KAI, C. DO-IL, S. BURTSEV, W. PELOUCH, E. ZAK, H. DE PEDRO, W. SZETO and H. FEVRIER. Transmission of 400G PM-16QAM channels over long-haul distance with commercial all-distributed Raman amplification system and aged standard SMF in field. In: *Optical Fiber Communications Conference and Exhibition*. San Francisco: OSA, 2014, pp. 1–3. ISBN 978-1-4799-5731-6. DOI: 10.1364/OFC.2014.Tu2B.1.
- [19] ZHOU, X., L. E. NELSON, P. MAGILL, R. ISAAC, Z. BENYUAN, D. W. PECKHAM, P. I. BOREL and K. CARLSON. High Spectral Efficiency 400 Gb/s Transmission Using PDM Time-Domain Hybrid 32-64 QAM and Training-Assisted Carrier Recovery. *Journal of Lightwave Technology*. 2013, vol. 31, iss. 7, pp. 999–1005. ISSN 1558-2213. DOI: 10.1109/JLT.2013.2243643.
- [20] DOWNIE, J. D., J. HURLEY and D. PIKULA. Transmission of 256 Gb-s<sup>-1</sup> PM-16QAM and 128 Gb-s<sup>-1</sup> PM-QPSK signals over long-haul and submarine systems with span lengths greater than 100 km. In: *39th European Conference and Exhibition on Optical Communication*. London: IET, 2013, pp. 1–3. ISBN 978-1-84919-759-5. DOI: 10.1049/cp.2013.1345.
- [21] AGALLIU, R. and M. LUCKI. Limits of advanced modulation formats for transition in fiber optic telecommunication systems to increase speeds from 10, 40, 100 Gb-s<sup>-1</sup> to higher bit rates. In: *Proceedings of SPIE 9131: Optical Modelling and Design III*. Brussels: SPIE, 2014, pp. 1–7. ISBN 978-1-84919-759-5. DOI: 10.1117/12.2054279.

## About Authors

**Rajdi AGALLIU** was born in 1989. He received his Master's degree from the Czech Technical University in Prague FEE in 2013. He is now completing his Ph.D. studies at the same faculty and his research interests include networking and optical communications.

**Michal LUCKI** was born in 1980. He received his M.Sc. from the Kielce University of Technology and Ph.D. from the Czech Technical University in Prague in 2004 and 2007, respectively. His research interests include photonics, fiber optics and solid state physics.