

## FAULT DIAGNOSIS IN DEAERATOR USING FUZZY LOGIC

S.Srinivasan<sup>1)</sup>, P.Kanagasabapathy<sup>1)</sup>, N.Selvaganesan<sup>2)</sup>

<sup>1)</sup> Department of Instrumentation Engineering,  
MIT Campus, Anna University, Chromepet, Chennai – 600044, India.

<sup>2)</sup> Department of EEE, Pondicherry Engineering College  
Pondicherry-605014, India

**Summary** In this paper a fuzzy logic based fault diagnosis system for a deaerator in a power plant unit is presented. The system parameters are obtained using the linearised state space deaerator model. The fuzzy inference system is created and rule base are evaluated relating the parameters to the type and severity of the faults. These rules are fired for specific changes in system parameters and the faults are diagnosed.

### 1. INTRODUCTION

Fault diagnosis concepts have increasingly gained attention over the last decade due to the demand for uninterrupted operation, higher safety and reliability standards. Powerful and at the same time, operator oriented supervision concepts are in demand in the industry now. Hence it is necessary to monitor the system operation continuously in order to detect and locate the faults promptly. The diagnostic systems should therefore allow reliable and early fault detection. A number of approaches have been proposed in recent years for the detection and diagnosis of failures in dynamic systems.

As stated in [1], the techniques used for fault detection and diagnosis can be divided into two methods namely, estimation of state variables and pattern recognition. In estimation method of state variables the method is based on the generation of residuals, which are given by the difference between the state variables estimated and the corresponding values in the nominal mode. The residuals can be generated in several ways, i.e. parity space, dedicated observer, fault detection filter [2], predictor model implemented with neural networks [3] and estimation of lumped parameters which are related to the physical process coefficients [4][5]. The pattern recognition is done in stages consisting of measurement, feature extraction and classification. The feature extraction generates a pattern, which is strictly related to actual mode of operation of the system. The classification is able to associate the actual pattern to one of the modes of operation of the system, which is previously defined. Fault diagnosis using fuzzy logic has reported in literature as in [6], which describes the combined analytical/fuzzy model-based fault diagnosis concept applied to high-pressure heater line.

This paper deals with the fault detection and diagnosis of a deaerator system represented in the linear state space model based on the parameter estimation. The parameters to be extracted are the set of lumped parameters of the state space model by the least square estimator [7]. A fuzzy logic system provides classification of the current pattern. This concept of fault diagnosis consists of two-steps.

First, one or several parameters are estimated which reflect faults in the process behavior. In the second step a decision has to be made by determining the severity and the location of the possible faults from the change in process parameters. The qualitative knowledge is employed in the fuzzy residual evaluation and taken into consideration in the rule base. Various faults are simulated in the deaerator model and the results obtained are presented in this paper.

The rest of the paper is divided into four sections. In section 2 the fault diagnosis concept using fuzzy logic has been explained. The system modeling is explained in section 3. The simulation of faults and the associated results are discussed in section 4. Finally we conclude with section 5.

### 2. FUZZY LOGIC BASED FAULT DIAGNOSIS CONCEPT

The fault diagnosis concept proposed here consists of the basic steps of parameter estimation, fuzzy expert system and fault presentation as shown in Fig. 1. The parameter estimation is based on analytical knowledge, i.e. a mathematical model and the available measurements. First of all the set of parameters are generated for complete system under supervision for which input and output measurements are available. These generated parameters give no direct information about the cause of the fault. These parameters with additional expert knowledge are then employed for fault detection in the fuzzy expert system. The fuzzy residual evaluation is a process that transforms quantitative knowledge of the parameters into qualitative knowledge (fault and severity). The design can be divided into three tasks namely fuzzification, inference and presentation of fault. The fuzzification describes the assignment of suitable number of fuzzy sets to each parameter component. This task is of major importance since it influences the detection properties. In the next step, each combination of parameters from the models has to be considered for the inference mechanism and a specific fault event has to be assigned. Several rules are framed based on the

parameter change and the type of fault. The objective for the fuzzy set is the detection of the eight possible faults of the deaerator. For a specific set of parameters as the input to the fuzzy inference system, rules are fired to give the type and severity of the fault. This is done using fuzzy conditional statement [8], which is of the form

IF (change=p1) AND IF (change=p2).....THEN (cause = fault 1)

The fuzzy decision transforms the fault knowledge of the process into the type of fault and severity of the fault is evaluated as the final task.

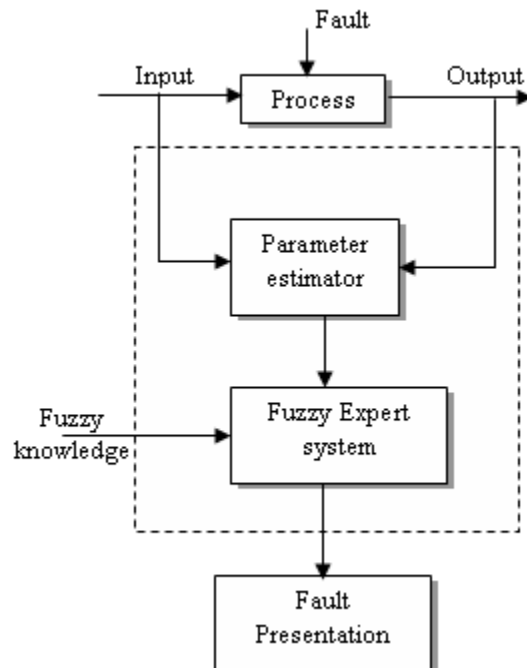

Fig. 1. Fault Diagnosis concept

### 3. SYSTEM MODELING

The deaerator is used in a power plant in order to avoid corrosion on internal surface of boiler tubes and drum. The gases dissolved in the feed water, particularly oxygen, are removed in the deaerator. The operation of the deaerator is based on the fact that the solubility of gases in water decreases as the temperature rises. If water is heated upto the saturation temperature and maintained at this temperature for a sufficient time, all gases can be removed and vented to atmosphere. In order to increase the deaerating efficiency, water is converted into small droplets through a system of spray nozzles and perforated trays. The deaerator is of combined spray, tray and reboiling type and is erected at a height of 27 meters from the ground. It consists of a vertical deaerating tower and a horizontal deaerating water storage tank as shown in Fig. 2. The tower is connected to the storage tank through two balance pipes. The deaerator is operated on a variable pressure mode. There are four perforated trays in the deaerating tower. The main

condensate enters the tower at the top and is divided into small droplets by means of spray nozzles. Then it is distributed uniformly over the trays. The steam extracted from the turbine is allowed to enter from the bottom of the tower. A safety valve is provided at the top of the tower to protect the tower from overpressure. A vacuum breaker is also provided at the top in order to avoid buckling of tower due to any possible vacuum.

The deaerator in general is a multivariable and nonlinear system. The state variables are pressure and enthalpy, the output variables are pressure and water level and the manipulated variables are condensate valve and steam valve positions. The resulting linearised state equations are in the form of

$$\dot{X} = AX(t)+BU(t) \quad (1)$$

$$Y(t) = CX(t)+DU(t) \quad (2)$$

The mathematical model developed by Abdennour et. al [9][10] is used to obtain the linearised discrete time model using the plant steady state data.. The nominal values of the variables of the deaerator are pressure  $P = 1.19\text{kg/cm}^2$ , enthalpy  $h = 292\text{kcal/kg}$ , condensate valve position  $y_c = 79.64\%$  (normally open), steam valve position  $y_s = 55.41\%$  (normally closed), level  $L = 1.62\text{m}$ . The state model for the deaerator system is as follows:

$$\begin{bmatrix} x_1(k) \\ x_2(k) \end{bmatrix} = \begin{bmatrix} -8.133\text{e-}003 & 0 \\ 4.066\text{e-}003 & 0 \end{bmatrix} \begin{bmatrix} x_1(k-1) \\ x_2(k-1) \end{bmatrix} + \begin{bmatrix} 1.661\text{e-}004 & -1.315\text{e-}004 \\ 8.308\text{e-}005 & -6.577\text{e-}005 \end{bmatrix} \begin{bmatrix} u_1(k-1) \\ u_2(k-1) \end{bmatrix} \quad (3)$$

$$\begin{bmatrix} y_1(k) \\ y_2(k) \end{bmatrix} = \begin{bmatrix} 3.620\text{e-}003 & 1.480\text{e-}005 \\ 5.150\text{e-}003 & 2.110\text{e-}005 \end{bmatrix} \begin{bmatrix} x_1(k-1) \\ x_2(k-1) \end{bmatrix} + \begin{bmatrix} 2.750\text{e-}004 & 6.920\text{e-}004 \\ 3.920\text{e-}004 & 9.859\text{e-}004 \end{bmatrix} \begin{bmatrix} u_1(k-1) \\ u_2(k-1) \end{bmatrix} \quad (4)$$

where  $x$ ,  $u$  and  $y$  are state, control and output vectors respectively. The equations are linearised around an equilibrium point (operating point). The linearisation depends on the five variables namely, pressure, enthalpy, feed water level, condensate valve position and steam valve position. In order to obtain the state space model for the system, we define  $x(t)$  as  $2 \times 1$  state vector,  $u(t)$  as  $2 \times 1$  input vector and  $y(t)$  as  $2 \times 1$  output vector.

$$X(t) = \begin{bmatrix} x_1(t) \\ x_2(t) \end{bmatrix} = \begin{bmatrix} P \\ h \end{bmatrix}$$

$$U(t) = [y_c \ y_s]^T$$

$$Y(t) = [P \ L]^T$$

A P+I+D controller with  $K_p = 0.795$ ,  $T_i = 1.75$  and  $T_d = 0.028$  is used for pressure loop and a P+I controller with  $K_p = 0.6$  and  $T_i = 3$  is used for the level loop.

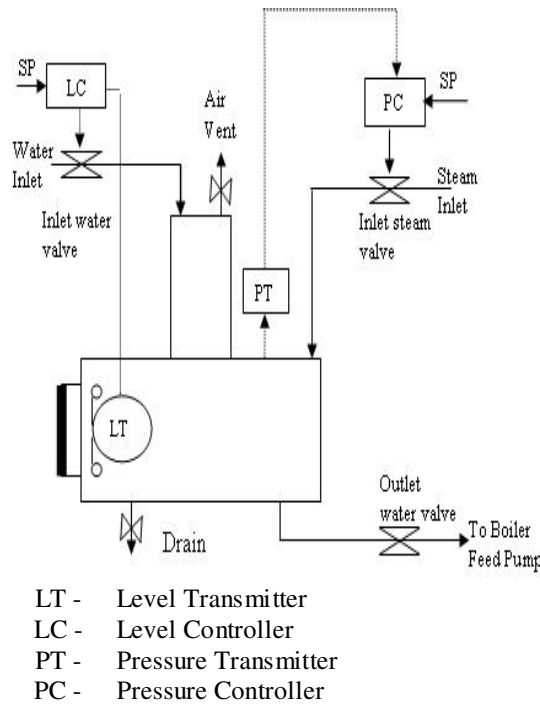

Fig. 2. Schematic diagram of a deaerator

**4. FAULT SIMULATION**

The fault identification for the deaerator is done off line. The mathematical model of the system is used to generate parameters, which are affected by possible faults. It has been noted that for every specified fault only A and B parameters get altered. In this paper eight of these parameters are generated from the model. They are all the system defining parameters in the state space model such as a11, a12, a21 and a22 from A matrix and b11, b12, b21, and b22 from B matrix.

**4.1. Membership Functions**

All membership functions for fuzzy expert system i.e., a11, a12, a21, a22, b11, b12, b21, and b22 and the output are defined in the common interval [S-15, S15]. A symmetric triangular shape with equal base and 50% overlap with neighbors are used for the membership functions. Fig. 3 represents the membership function for b21. This is the most natural and unbiased choice for membership functions. The numbers of membership functions considered are thirty and it is decided upon the number of single and double faults. The membership functions can be reduced to nine or six but the problem is that the severity of the fault will not be represented accurately, which is additional information we get when compared to the neural network based fault diagnosis system. Hence, in order to represent the severity of the fault, the number of membership function has to be increased. The severity of the single fault simulated is upto ±10%. The fault diagnosis system for the deaerator will have eight system parameters as the input and eight outputs, as shown in Fig. 4. The output of the

fuzzy system are the eight fault namely, leakage in the tank, negative bias in the water valve, positive bias in the water valve, negative bias in the steam valve, positive bias in the steam valve, sedimentation deposit, water mixing with water in preheater and inlet water temperature is high. Double fault is the occurrence of

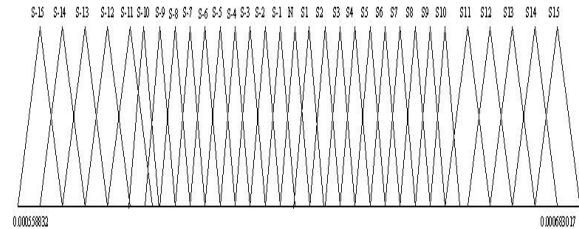

Fig. 3. Membership function for b21 (S-15 represent ±15% severity)

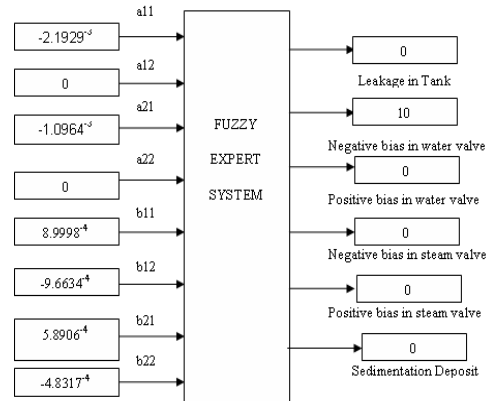

Fig. 4. Fuzzy fault diagnosis system

1. Sedimentation deposit with negative and positive bias in Water valve, negative and positive bias in steam valve, temperature of inlet water is less and steam mixing with water in preheater.
2. Leakage in the tank with negative and positive bias in Water valve, negative and positive bias in steam valve, temperature of inlet water is less and steam mixing with water in preheater.
3. Positive bias in water valve with negative and positive bias in steam valve, temperature of inlet water is less and steam mixing with water in preheater.
4. Negative bias in water valve with negative and positive bias in steam valve, temperature of inlet water is less and steam mixing with water in preheater.
5. Negative bias in steam valve with temperature of inlet water is less and steam mixing with water in preheater.
6. Positive bias in steam valve temperature of inlet water is less and steam mixing with water in preheater.

The input parameters are bound to change during the occurrence of fault. The output representation from the fuzzy system will be either single or double fault with its severity.

#### 4.2. The Rule Base

The rule base in the fuzzy inference system for single faults is framed as follows:

- R1. If a11 is s10 and a21 is s10 and b11, b12, b21, b22 are normal then fault is leakage in the tank and the magnitude of leakage is 10%.
- R2. If a11 is s-10 and a21 is s-10 and b11, b12, b21, b22 are normal then the fault in sedimentation deposit and the magnitude of the deposit is 10%.
- R3. If a11, a21 and b11 are normal and b12 is s-6 and b21 is normal and b22 is s-5 then the fault is steam valve failure with positive bias and its severity is 3%.
- R4. If a11, a21 and b11 are normal and b12 is s4 and b21 is normal and b22 is s4 then the fault is steam valve failure with negative bias and its severity is 2%.
- R5. If a11, a21 and b11 are normal and b12 is s5 and b21 is s5 and b22 is s5 then the fault is condensate valve failure with negative bias and its severity is 5%.
- R6. If a11, a21 and b11 are normal and b12 is s-5 and b21 is s-5 and b22 is s-5 then the fault is condensate valve failure with positive bias and its severity is 5%.
- R7. If a11 and a21 are normal and b11 is s-1 and b12 is s-6 and b21 is s-2 and b22 is s-2 the fault is temperature of the inlet water is less and its severity is 1%.
- R8. If a11 and a21 are normal and b11 is s2 and b12 is s11 and b21 is s4 and b22 is s4 the fault is steam mixing with water in preheater and its severity is 2%.
- R9. If a11 is s10 and a21 is s10 and b11 is normal and b12 is s5 and b21 is s5 and b22 is s5 then the fault is leakage in the tank with condensate valve failure (negative bias) and the severity of leakage in the tank is 10% and condensate valve failure is 5%.
- R10. If a11, a21 and b11 are normal and b12 is s-5 and b21 is s5 and b22 is s-3 then the failure is steam valve failure and Condensate valve failure with a severity of 3% and 5% respectively.
- R11. If a11 is s-10 and a21 is s-10 and b11 is s2 and b12 is s11 and b21 is s4 and b22 is s4 the fault is sedimentation deposit with steam mixing with water in preheater and their severity are 10% and 2% respectively.
- R12. If a11 and a21 are normal and b11 is s-1 and b12 is s-9 and b21 is s-2 and b22 is s-8 then the failure is steam valve failure with positive bias with a severity of 3% and temperature of the inlet water is less and its severity is 1%

A total number of 850 rules have been framed for single and double fault with a maximum severity of 10% and 5% respectively. Tab. 1 represents the range of parameters for the occurrence of the single fault. The range of parameters for the occurrence of double faults is a11 [-0.002412281 -0.001973684], a12 [0 0], a21 [-0.00120614 -0.000986842], a22 [0 0], b11 [0.000809987

0.000989984], b12 [-0.001116669 -0.000854646], b21 [0.000530155 0.000716355], b22 [-0.000558334 -0.000427323]. Thus for a specific set of input parameters, single and double faults are diagnosed using fuzzy based diagnosis scheme.

#### 4.3. Simulation Results

A decrease in outlet flow will be seen during the sedimentation deposit in the outlet water pipe. This is simulated by decreasing the outlet flow by 10% at 10000<sup>th</sup> instant. It can be seen from the graph that level increases and due to which the pressure also increases. The water leakage in the tank is shown by 10% increase in output flow at 20000<sup>th</sup> instant. As the flow get reduced to the high pressure preheater, the demand is satisfied by the increase in the opening of the outlet control valve and a decrease in level due to which the pressure also decreases. Both the faults are represented in Fig. 5.a and Fig. 5.b.

The inlet water valve to the deaerator is normally closed type. The positive and negative bias in the inlet water valve will cause an increase and decrease in flow rate respectively. The negative bias to the valve is introduced by increasing the condensate pressure, the pressure upstream to the water inlet valve, and the positive bias is simulated by decreasing the condensate pressure. The negative bias will create a decrease in flow rate, which will cause a decrease in pressure and level in the deaerator, which is simulated at 10000<sup>th</sup> instant. The positive bias is simulated at 20000<sup>th</sup> instant, which causes a increase in pressure and level in the deaerator. Both the faults are represented in Fig. 6.a and Fig. 6.b and the severity of both the fault are 5%.

The inlet steam valve to the deaerator is a normally open type. The positive and negative bias in the inlet steam valve will cause an increase and decrease in flow rate respectively. The negative bias to the valve is introduced by increasing the steam pressure by 3% at 10000<sup>th</sup> instant, the pressure upstream to the steam inlet valve, and the positive bias is simulated by decreasing the steam pressure by 2% at 20000<sup>th</sup> instant. Both the faults are represented in Fig.7.a and Fig.7.b. In the case of negative bias as the pressure decreases the level has to increase but the pressure reduces dramatically so that evaporation takes place and level start decreasing.

The mixing of steam with water in preheater will increase the temperature of the inlet water. This causes an increase in pressure and level in the deaerator tank. The simulation is done, by increasing the enthalpy of the inlet water by 10% at 10000<sup>th</sup> instant. The decrease in temperature to the deaerator can be represented by decrease in enthalpy of the water by decreasing the enthalpy of inlet water by 10% at 20000<sup>th</sup> instant. The response is represented in Fig. 8.a Fig.8.b.

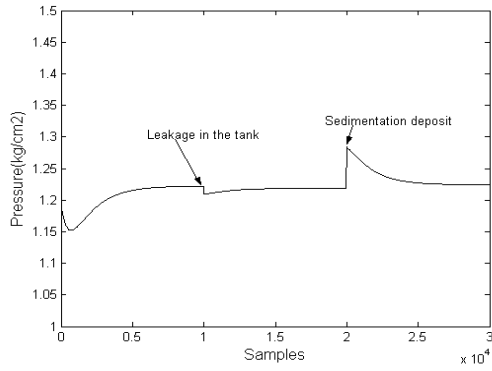

Fig. 5a 10% variation in  $w_1$  reflected in output 1 (pressure)

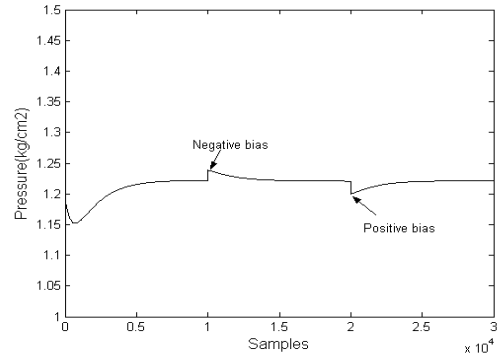

Fig. 7a 10% variation in  $P_s$  reflected in output 1

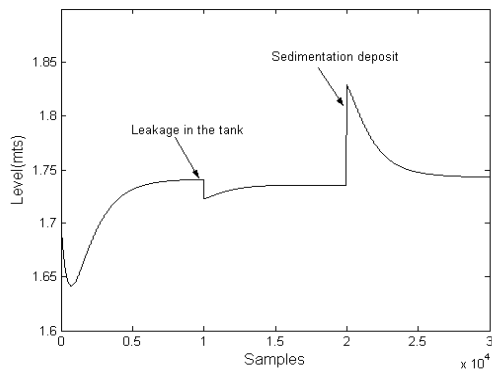

Fig. 5b 10% variation in  $w_1$  reflected in output 2 (Level)

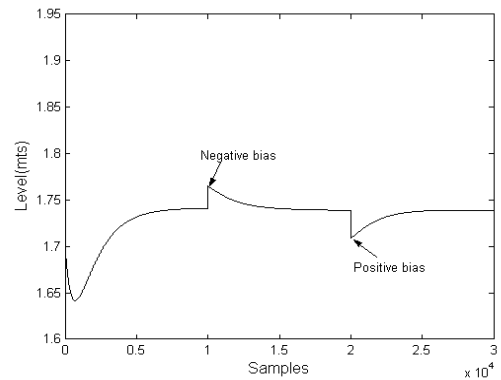

Fig. 7b 10% variation in  $P_s$  reflected in output 2

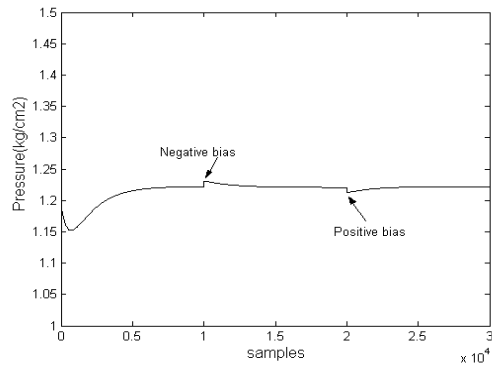

Fig. 6a 10% variation in  $P_c$  reflected in output 1

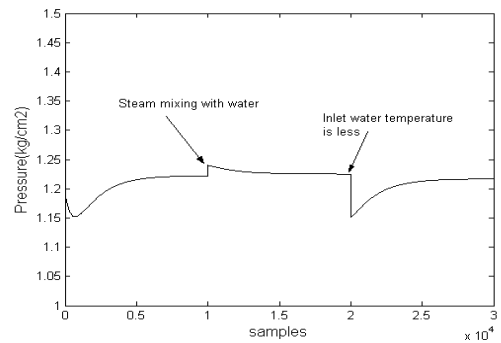

Fig. 8a 10% variation in  $h_e$  reflected in output 1

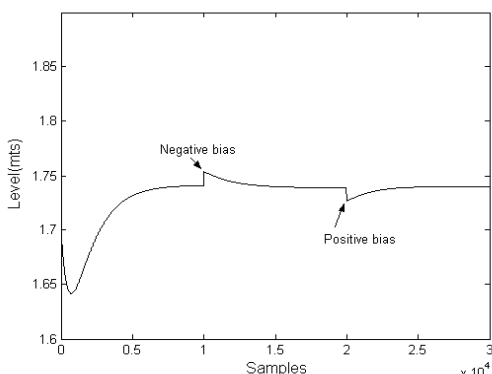

Fig. 6b 10% variation in  $P_c$  reflected in output 2

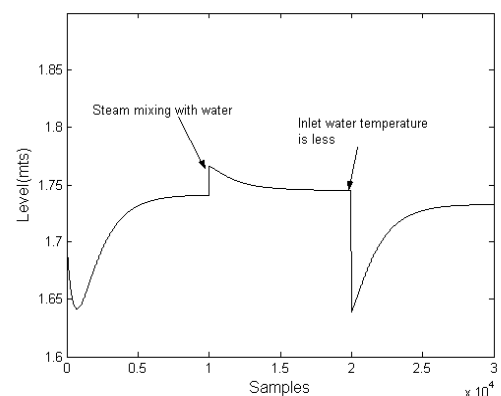

Fig. 8b 10% variation in  $h_e$  reflected in output 2

## 5. CONCLUSION

This paper describes the fault diagnosis concept based on analytical and expert knowledge to a deaerator system. The parameters are evolved for the normal and abnormal conditions from the analytical model. From the estimated parameters the single and double faults are identified by the set of rule base in fuzzy inference system using expert knowledge. The result shows that the fuzzy system was able to identify the faults accurately with its severity. This is the additional feature of the fuzzy based approach where the severity of the faults can be represented compared to the neural network approach where the type of faults alone can be represented.

### Acknowledgement

The authors thank the M/S Madras Fertilizers Limited, Chennai for providing the data of the 110 Atm deaerator supplied by M/S Thermax Pune.

### REFERENCES

- [1] SORSA, T. et al.: Neural networks in process fault diagnosis, IEEE Trans. on System, Man and Cybernetics-part B, vol. **21**, No. 4, 1991, pp. 815-825.
- [2] FRANK, P.M: Fault diagnosis in dynamic systems using analytical and knowledge- based redundancy: a survey and some new results, Automatica, vol. **26**, No.3, 1990, pp. 459-474.
- [3] SORSA, T. et al.: Fault diagnosis of dynamic systems using neural networks, 12<sup>th</sup> IFAC world conference Sydney Australia, vol.7, July 1993, pp. 453-456.
- [4] QING ZHAO et al.: "Design of a novel Knowledge-Based Fault Detection and Isolation Scheme", IEEE Trans. on System, Man and Cybernetics-part B vol. **34**, No.2, April 2004, pp.1089-1095.
- [5] ISERMANN, R.: On the application of model-based fault detection for technical processes, Control Eng. Practice, vol. **2**, No.3, 1994, pp. 439-450.
- [6] KOPPEN-SELIGER, B. et al.: A Fault Diagnosis Concept for a High-Pressure-Preheater Line, 34<sup>th</sup> conference on decision and control, New Orleans, December 1995, pp. 2383-2388.
- [7] JANIKARAMAN. P.A., RENGANATHAN. S: A new on-line identification method for discrete multivariable linear systems, Automatica, Vol. **17**, No. 4, 1981, pp. 653-655.
- [8] Kelvin Self, IEEE spectrum: Designing with Fuzzy Logic", Vol. **42**, No. 44, 1990, p. 105.
- [9] ADEL BEN- ABDENNOUR et al.: Multivariable robust control of a power plant deaerator, IEEE Transactions on Energy conversion, Vol. **8**, No.1, March 1993, pp. 123-129.
- [10] ORDYS A.W. et al.: Modelling and Simulation of Power generation plants, Springer-Verlag, London, 1994.

Table 1. Range for single fault

Types of Faults	a11		a12	a21		a22
	Min	Max		Min	Max	
Sedimentation Deposit	$-2.1929 \times 10^{-5}$	$-2.4122 \times 10^{-3}$	0	$-1.0964 \times 10^{-3}$	$-1.2061 \times 10^{-3}$	0
Leakage in the Tank	$-2.1710 \times 10^{-3}$	$-1.9736 \times 10^{-3}$	0	$-1.0855 \times 10^{-3}$	$-9.8684 \times 10^{-4}$	0
Negative Bias in Water inlet valve	$-2.1929 \times 10^{-3}$	$-2.1929 \times 10^{-3}$	0	$-1.0964 \times 10^{-3}$	$-1.0964 \times 10^{-3}$	0
Positive Bias in Water inlet valve	$-2.1929 \times 10^{-3}$	$-2.1929 \times 10^{-3}$	0	$-1.0964 \times 10^{-3}$	$-1.0964 \times 10^{-3}$	0
Negative Bias in Steam valve	$-2.1929 \times 10^{-3}$	$-2.1929 \times 10^{-3}$	0	$-1.0964 \times 10^{-3}$	$-1.0964 \times 10^{-3}$	0
Positive Bias in Steam Valve	$-2.1929 \times 10^{-3}$	$-2.1929 \times 10^{-3}$	0	$-1.0964 \times 10^{-3}$	$-1.0964 \times 10^{-3}$	0
Temperature of inlet water is less	$-2.1929 \times 10^{-3}$	$-2.1929 \times 10^{-3}$	0	$-1.0964 \times 10^{-3}$	$-1.0964 \times 10^{-3}$	0
Steam Mixing with Water in preheater	$-2.1929 \times 10^{-3}$	$-2.1929 \times 10^{-3}$	0	$-1.0964 \times 10^{-3}$	$-1.0964 \times 10^{-3}$	0

Table 1. Range for single fault (continue)

Type of Faults	b11		b12		b21		b22	
	Min	Max	Min	Max	Min	Max	Min	Max
Sedimentation Deposit	$8.999 \times 10^{-4}$	$8.9998 \times 10^{-4}$	$-9.8320 \times 10^{-4}$	$-9.8320 \times 10^{-4}$	$6.2092 \times 10^{-4}$	$6.2092 \times 10^{-4}$	$-4.9160 \times 10^{-4}$	$-4.9160 \times 10^{-4}$
Leakage in the Tank	$8.999 \times 10^{-4}$	$8.9998 \times 10^{-4}$	$-9.8320 \times 10^{-4}$	$-9.8320 \times 10^{-4}$	$6.2092 \times 10^{-4}$	$6.2092 \times 10^{-4}$	$-4.9160 \times 10^{-4}$	$-4.9160 \times 10^{-4}$
Negative Bias in Water inlet valve	$8.9998 \times 10^{-4}$	$8.9998 \times 10^{-4}$	$-9.8155 \times 10^{-4}$	$-9.6634 \times 10^{-4}$	$6.1781 \times 10^{-4}$	$5.8906 \times 10^{-4}$	$-4.9077 \times 10^{-4}$	$-4.8317 \times 10^{-4}$
Positive Bias in Water inlet valve	$8.9998 \times 10^{-4}$	$8.9998 \times 10^{-4}$	$-9.9923 \times 10^{-4}$	$-9.8483 \times 10^{-4}$	$6.5123 \times 10^{-4}$	$6.2402 \times 10^{-4}$	$-4.9241 \times 10^{-4}$	$-4.9961 \times 10^{-4}$
Negative Bias in Steam valve	$8.9998 \times 10^{-4}$	$8.9998 \times 10^{-4}$	$-9.7991 \times 10^{-4}$	$-9.4960 \times 10^{-4}$	$6.2092 \times 10^{-4}$	$6.2092 \times 10^{-4}$	$-4.8995 \times 10^{-4}$	$-4.7480 \times 10^{-4}$
Positive Bias in Steam Valve	$8.9998 \times 10^{-4}$	$8.9998 \times 10^{-4}$	$-1.0151 \times 10^{-3}$	$-9.8646 \times 10^{-4}$	$6.2092 \times 10^{-4}$	$6.2092 \times 10^{-4}$	$-4.9323 \times 10^{-4}$	$-5.0757 \times 10^{-4}$
Temperature of inlet water is less	$9.0898 \times 10^{-4}$	$8.0991 \times 10^{-4}$	$-9.9303 \times 10^{-4}$	$-8.8488 \times 10^{-4}$	$6.2713 \times 10^{-4}$	$5.5883 \times 10^{-4}$	$-4.9651 \times 10^{-4}$	$-4.4244 \times 10^{-4}$
Steam Mixing with Water in preheater	$9.8998 \times 10^{-4}$	$8.9098 \times 10^{-4}$	$-9.7336 \times 10^{-3}$	$-1.0815 \times 10^{-3}$	$6.1471 \times 10^{-4}$	$6.8301 \times 10^{-4}$	$-4.8668 \times 10^{-4}$	$-5.407 \times 10^{-4}$